



Liquefaction

 Clean Fuel

ECOSPRAV
technologies for the planet

Liquefaction



Clean Fuel

Turnkey solutions for the liquefaction of biomethane and methane - BIO-LNG - as high-quality fuel for automotive and ship transport, with reduced environmental impact.

Ecospray micro-liquefaction systems, starting from 2 tons / day, are easy to install, modularized, skid-mounted and containerized. Customized solutions are also available, based on the specific production needs of the customer.

The process is based on the compression and expansion of methane or biomethane to reach the temperatures of liquefaction without use of nitrogen and other refrigerants, thus independent from third parties.

Benefits



Supporting the circular economy and the decarbonization thanks to on-site production and supply of green fuel and sustainable energy.



Modular configuration, based on a 40-foot skid, which allows ease and quick installation, a completely automated and remote-control system management.



Increased economic benefits with low OPEX and CAPEX per Ton of produced LNG.

Overview

From gas to liquid: the micro-liquefaction of biomethane and natural gas into BIO-LNG and LNG.

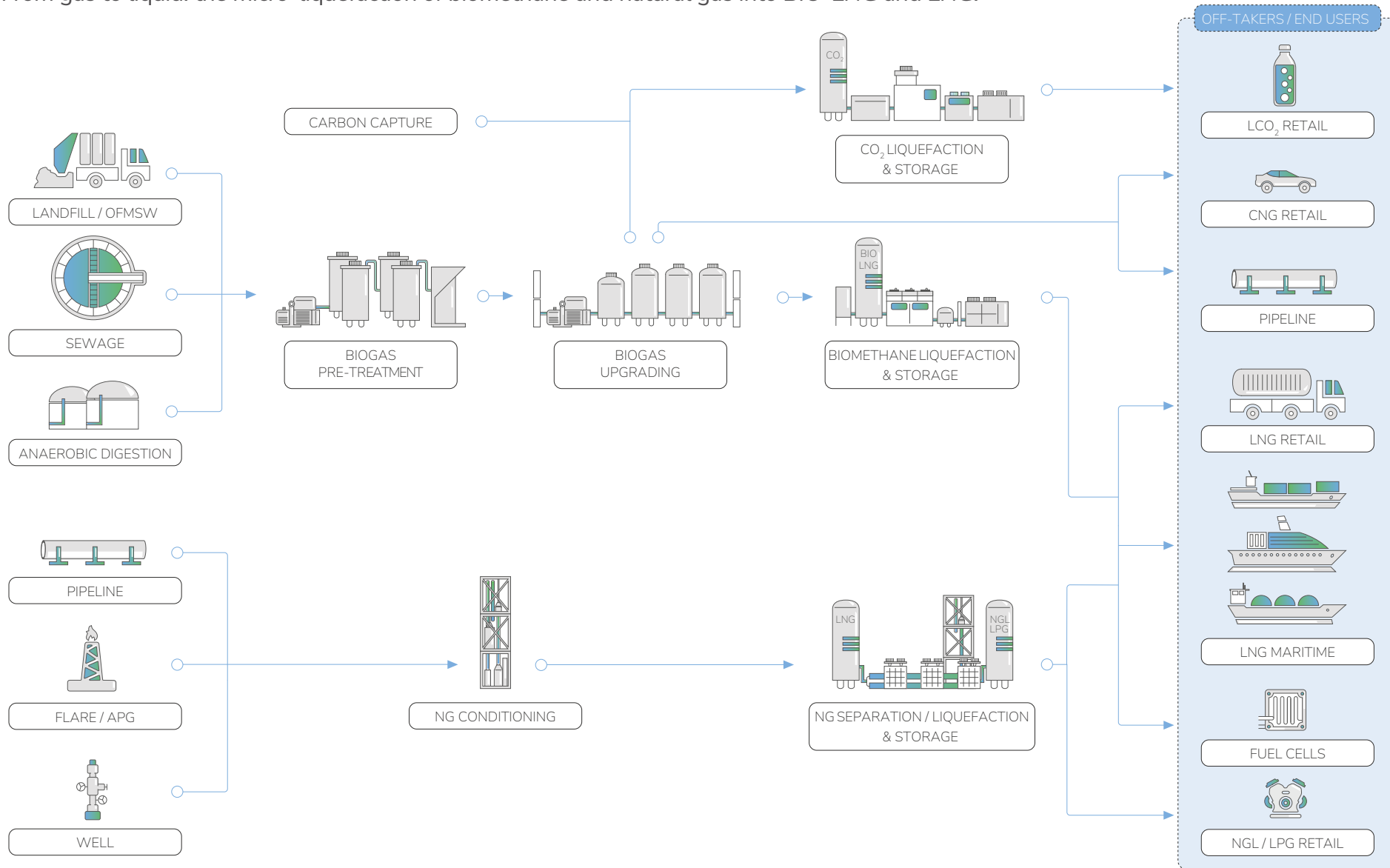

Overview

Why choose our systems: from the flange to the distributor.

Biogas

Our advanced solutions for power generation and sustainable fuels allow converting agricultural biogas plants to BIO-LNG production, which makes them economically “profitable”.

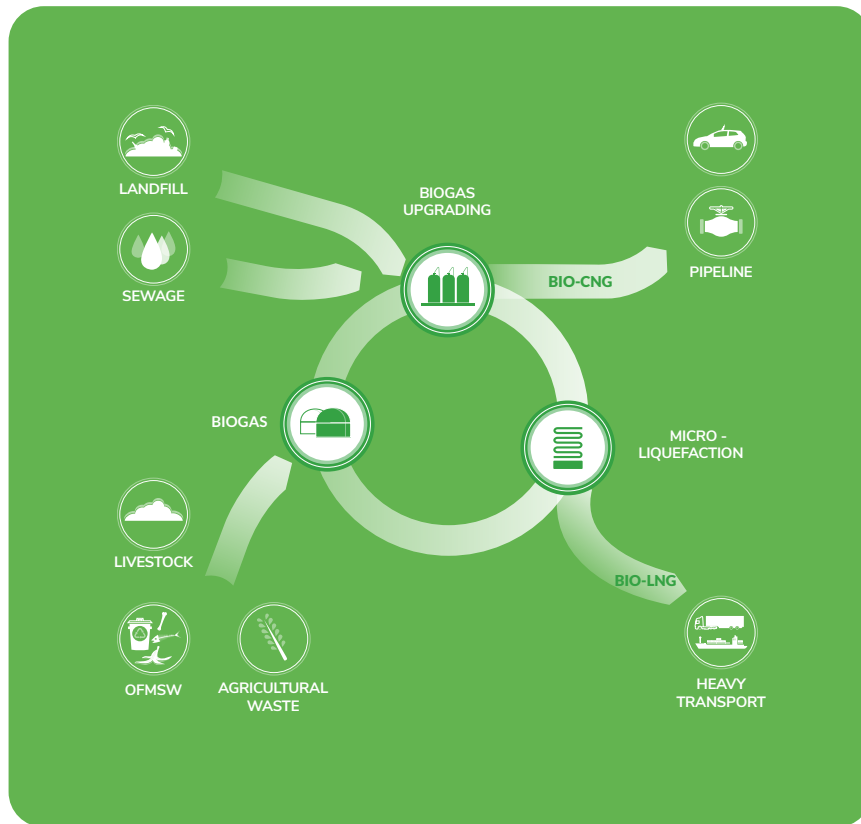

Natural gas

On-site production, e.g. from pipelines, avoiding the transport of the product from the storage terminals, significantly reduce logistic costs, unforeseen events and associated emissions from road transport of the product.

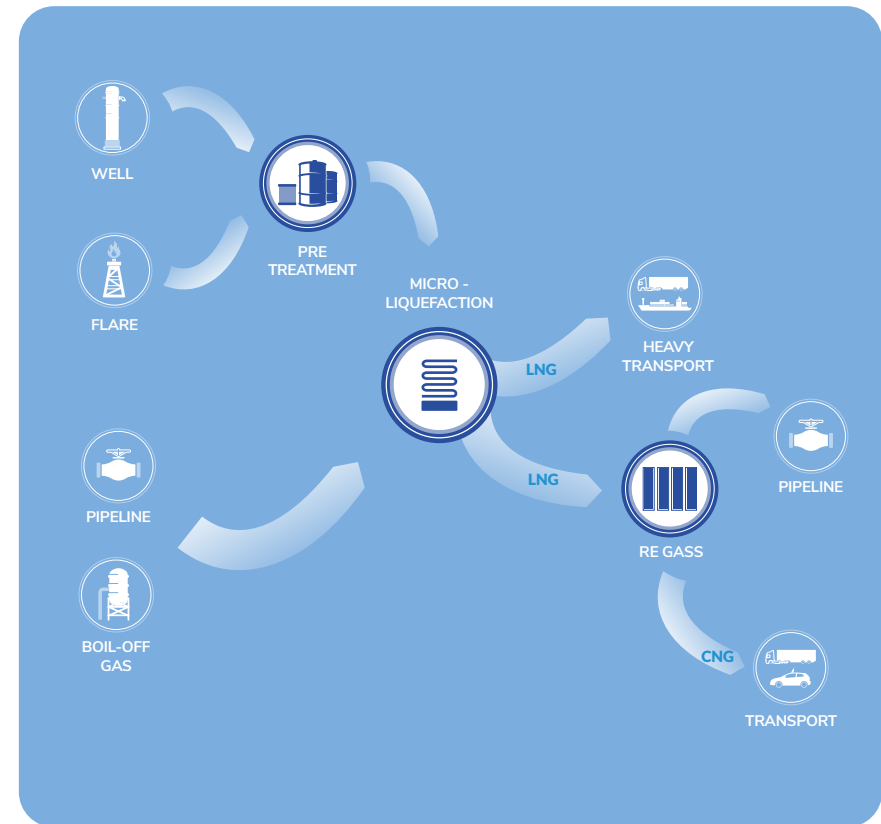

How it works

Liquefaction is based on gas compression and expansion by means of JT valves, and uses multiple pressure stages depending from the fluid flow rate to be liquefied.

1. The inlet biomethane/methane has to be made compliant with liquefaction specifications (to avoid ice formation) by eliminating carbon dioxide and humidity in the polishing unit (series of reactors containing molecular sieves alternately regenerated); the produced off-gas, in the case of biomethane, is entirely recirculated upstream of the upgrading system, thus avoiding methane losses along the whole process of liquefaction.
2. The purified biomethane is compressed to 100 bar and pre-cooled in a chiller.
3. In the cryogenic section the flow rate of biomethane is separated into two streams: the cooling one, which is expanded via a JT valve, and the main stream that is cooled in the heat exchanger.
4. Two or three stages of expansion and cooling of the gas, allow to reach temperatures below -150°C and produce liquefied biomethane which is stored in a special cryogenic tank.

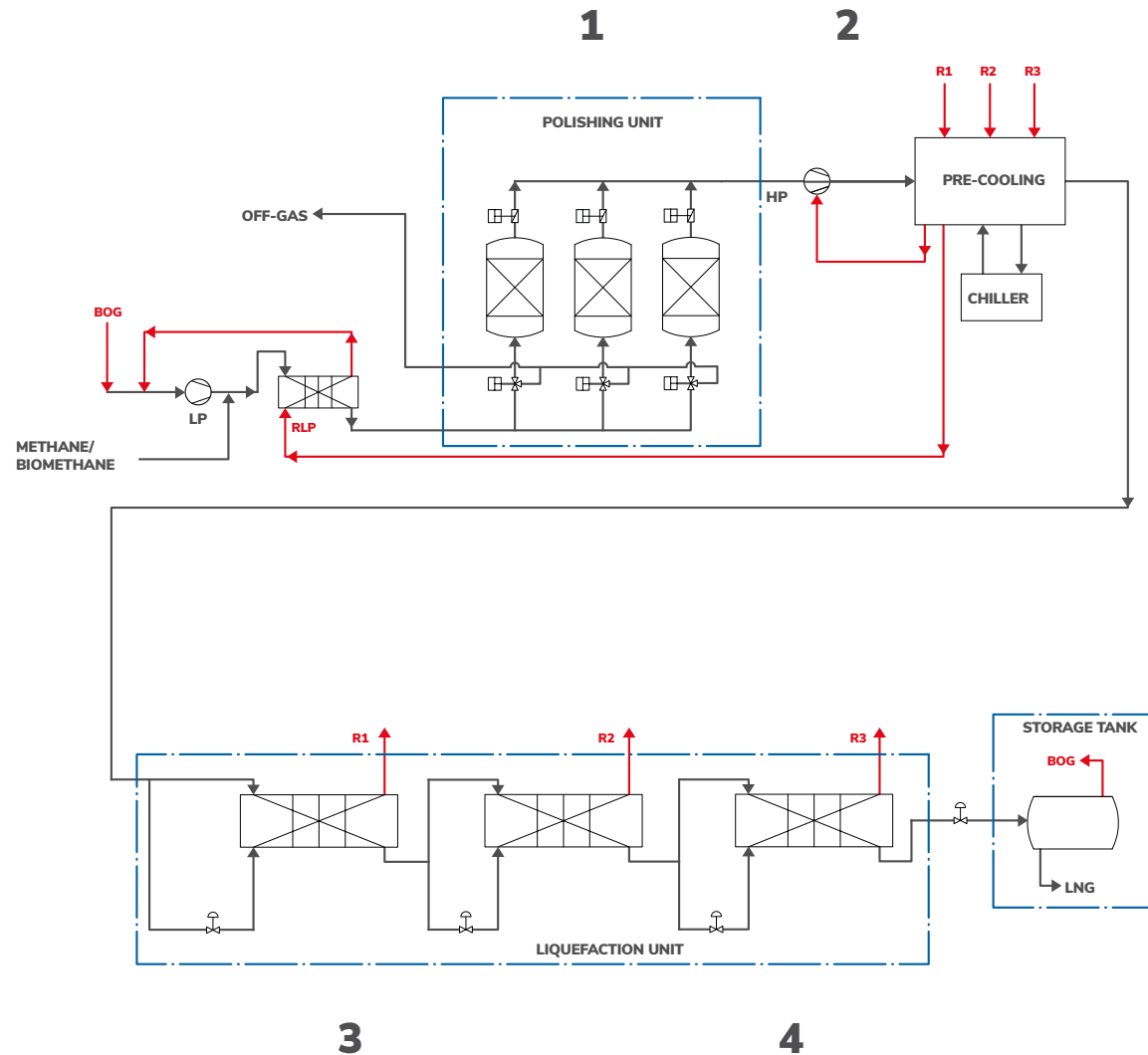

Key features

Ecospray liquefaction systems feature:

- **Simplicity:** absence of additional cooling fluids
- **Efficiency:** low specific energy consumption
- **Flexibility:** able to partialize the flow of methane or biomethane
- **Automation:** unattended operations thanks to remote control and interconnection
- **Compactness:** design organized in standard format skid, adaptable to the shape and space available, easily transportable and relocatable
- **Modularity:** possibility to adapt and size the system according to production needs. Possibility to integrate others complementary treatments and systems, such as:



Novi Ligure - Landfill managed by SRT S.p.A Biogas upgrading + biomethane liquefaction & storage

Pre-treatment

This system removes H_2S , VOC and other contaminants, prior the conversion into biomethane. The system uses activated carbon beds in double configuration to ensure the continuity and effectiveness of the process. Appropriate dehumidification systems remove any excess water contained in the gas.

Biogas Upgrading

Based on VPSA technology (Vacuum Pressure Swing Adsorption), the system operates at ambient pressure ensuring high efficiency and low consumption. The biogas upgrading system removes CO_2 without the use of chemicals, and produces biomethane with a high CH_4 content (> 97%).

Nitrogen Rejection Unit

Solution for the selective absorption of either Methane (released at low pressure) or Nitrogen, depending the biogas composition. With a high tolerance for biogas impurities fluctuations and with the low cost of adsorbent material, this system has simplified operational and maintenance activities.

Technical Specifications

- System designed and built in two or more skids depending on size, size standard, 40ft container type - 12.2 x 2.4 x 2.8 mt (LxWxH)
- Compatible with existing biomethane plants, equipped with upgrading technologies different from VPSA (membranes, water or chemical scrubbers, amines, etc)
- Production of BIO-LNG / LNG at temperatures of $-150 \div -155$ ° C and pressures of $2 \div 3$ bar (g).
- No use of external refrigerants (e.g. nitrogen or mixed refrigerants) or other utilities
- Reduced electricity consumption (<1 kWh / kg of BIO-LNG /LNG produced), and no need for water either heat for the process
- Automated system control, with latest generation PLC. Completely remotely supervised and Industry 4.0 ready
- Highly configurable control system, with different communication interfaces available (ModBus, ProfiBus, ProfiNet, Profisafe)
- Including the quality / quantity analysis system of BIO-LNG / LNG produced
- Integrated with the storage and off-loading system of BIO-LNG / LNG on transport tanks

BIO-LNG					
Equivalent CHP Power	kWe	500	1.000	2.000	3.000
Biogas	Nm ³ /h	250	500	1.000	1.500
Biomethane	Nm ³ /h	145	290	580	880
BIO-LNG	ton/d	2,4	4,8	9,7	14,5
User Power	kWe	210	360	660	950

Note: indicative values with CH₄ content in biogas equal to 55%, values for complete system (upgrading and liquefaction)

LNG				
Natural Gas	Nm ³ /h	500	1.000	2.300
LNG	ton/d	8,7	17,5	42,0
Used Power	kWe	330	640	1.240

Note: indicative values assuming a content of heavy hydrocarbons in the gas grid $<5\%$ and 12 bar network pressure.



Layout

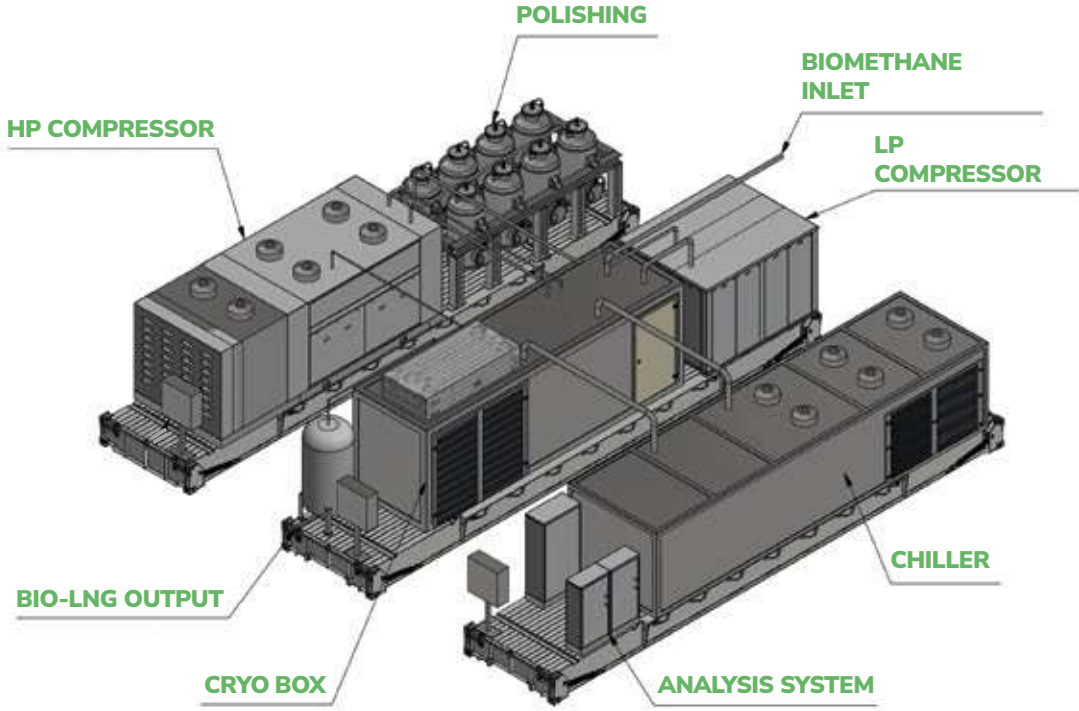
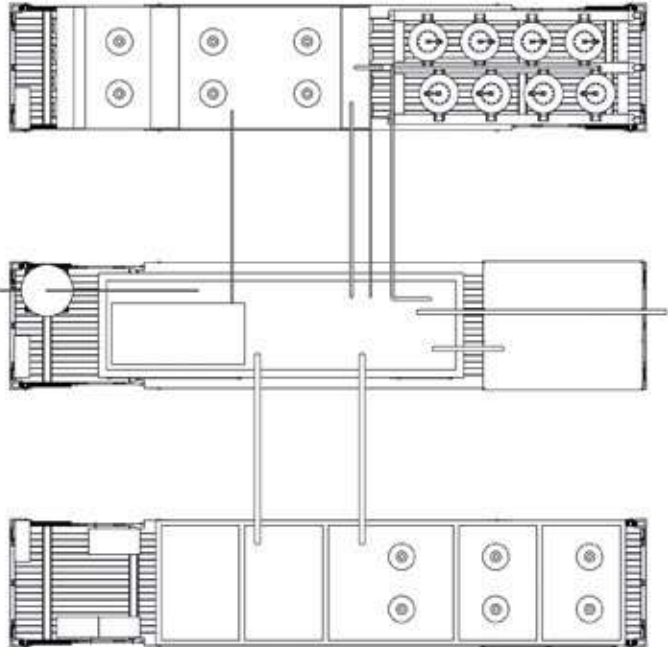
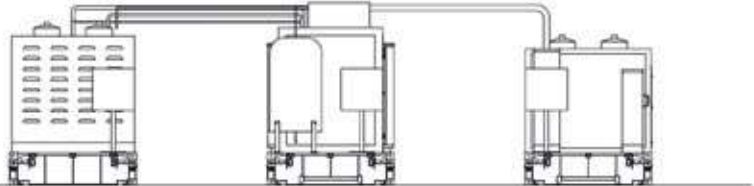
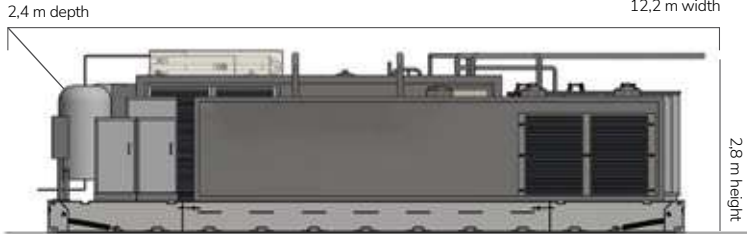

Service

Thanks to our 360 ° approach we are able to follow our customers along the entire value chain, starting from the feasibility study up to after-sales services, with the possibility of financing and/or “pay per use” payments for full-service contracts.

With One, the new digital cloud solution developed by Ecospray to ensure proactive monitoring and 24/7 operations, our team of technicians can monitor systems in real-time, optimizing the maintenance process and system management and their performances.



Liquefaction



Technology Map



Exhaust Gas Cleaning

Advanced DeSox

Exhaust Gas Cleaning Systems

Catalytic Abatement

DeNO_x SCR
Diesel Oxidation Catalyst
Methane Slip Reduction

Filtration

Wet Electrostatic Precipitator
Diesel Particle Filtration
Filter Cassettes



Carbon Capture

Carbon Capture and Sequestration

Scrubbing with Ammine
Scrubbing with Calcium Hydroxide
Molten Carbonate Fuel Cells

Liquefaction

CO₂ Liquefaction



Clean Fuel

Pre-Treatment and Upgrading

Smart Blending
Pre-Treatment
Biogas Upgrading

Liquefaction

Biomethane Liquefaction
Natural Gas Liquefaction
Nitrogen Rejection Unit



Green Power Generation

Lean Gas To Power

Lean Gas To Power



Get in Touch. Book a Meeting.

Our experts are available to schedule a web call to explain any detail around our technology and solutions.

[Book Online](#)

or call **+39 0131 854611**

ECOSPRAY

technologies for the planet

Via Circonvallazione, 14/14A
15050 - Alzano Scrivia (AL)
+39 0131 854611
info@ecospray.eu
ecospray.eu